

Company Information



Headquarters and Assembly Line at Bückeberg-Röcke



Plant - CNC Production at Bückeberg-Müdingen



Plant - Helsen

PRECIMA Magnettechnik GmbH was founded in the year 1981 and is today established as an independent, medium sized, innovative family owned brake manufacturer. With our staff of more than 160 employees we develop and produce a wide range of electro-magnetic operated brakes and clutches for all kinds of applications in machine and other industries. Our standard range of products covers a performance scope of braking torques between 0.5 and 1,600 Nm.

Thanks to our advanced CNC machining technology and well organized assembly lines we produce more than 550,000 units per year. The high rate of self manufactured parts provides us with a maximum of flexibility and allows for short response times.

Our own highly qualified and experienced engineering and development departments are specialized in producing customized brake solutions on a very high technical and economic standard.



Fail-Safe Electromagnetic Motor Brakes
FDX Series
IP 67 Seawater proof



The new FDX series is a completely enclosed robust IP67 spring applied failsafe brake.

The new FDX series was specially designed for those applications involving harsh ambient conditions like offshore equipment.

All FDX parts are manufactured from robust and corrosion resistant materials and the IP67 enclosure ensures the protection of the internal working parts over its lifetime, from any outside influence.

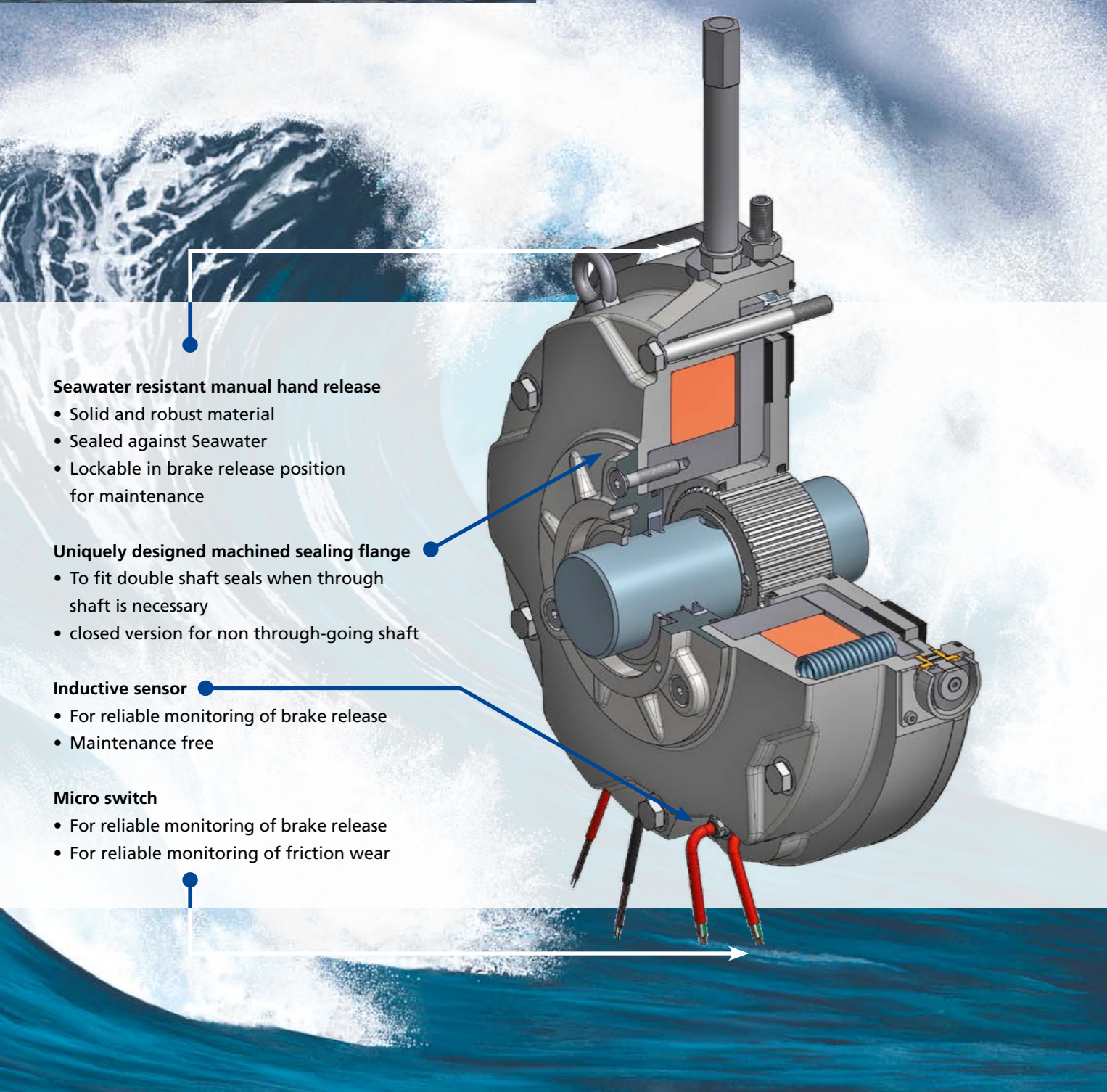

Seawater resistant manual hand release

- Solid and robust material
- Sealed against Seawater
- Lockable in brake release position for maintenance

Uniquely designed machined sealing flange

- To fit double shaft seals when through shaft is necessary
- closed version for non through-going shaft

Inductive sensor

- For reliable monitoring of brake release
- Maintenance free

Micro switch

- For reliable monitoring of brake release
- For reliable monitoring of friction wear

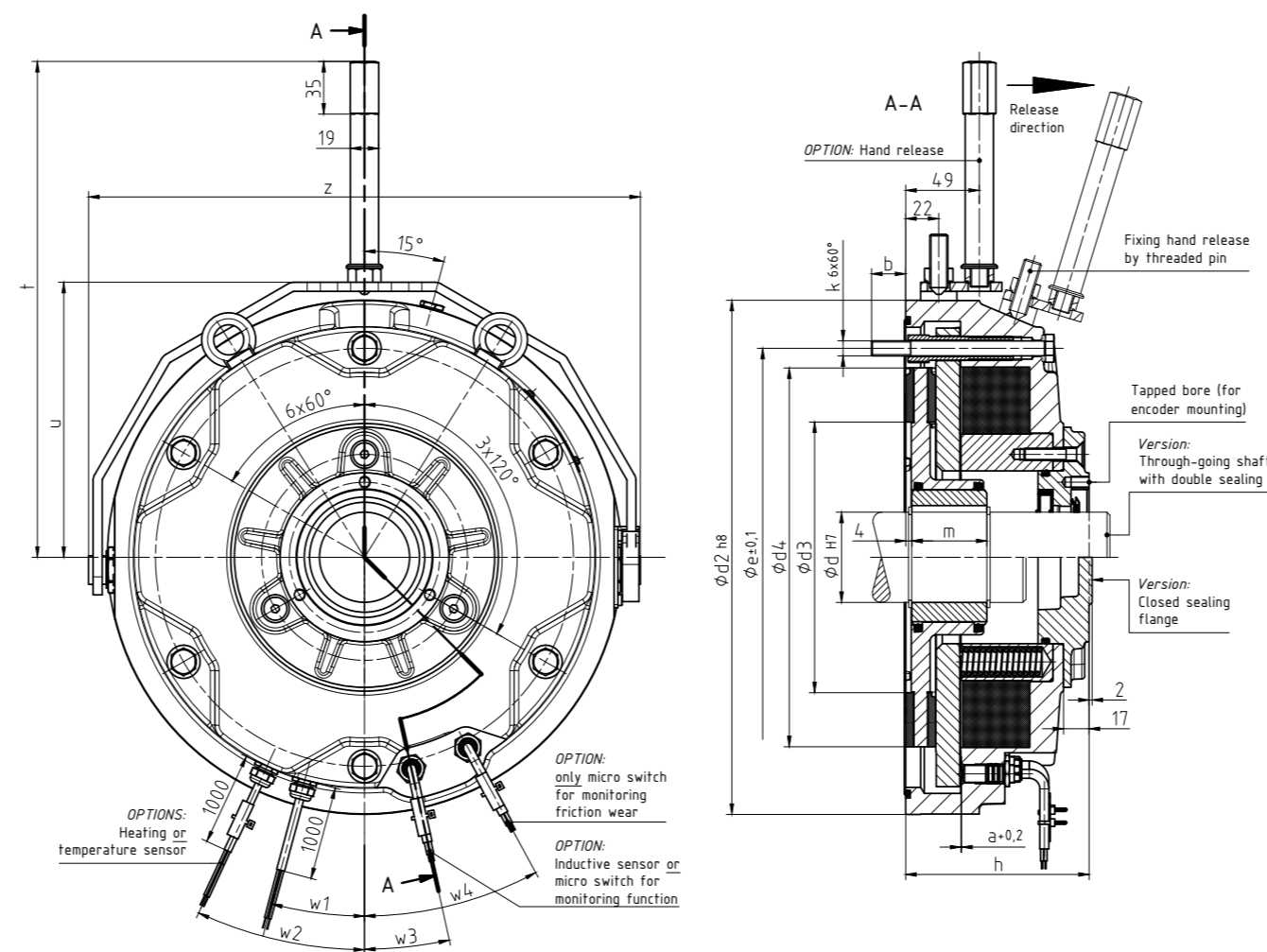

Size	Max. Nominal braking torque (Nm)	a (+0,2)	b	ød H7	ød2 (h8)	ød3	ød4
FDX 26	250 / 375*)	0,5	24,5	40/45/50/55**	294	130	204
FDX 30	500 / 850*)	0,5	22,5	50/55/60/65**	342	180	255
FDX 40	1000 / 1500*)	0,6	22	65/70/75/80**	436	258	330

Size	øe (±0,1)	h	k (6 x 60°)	m	t	u	w1	w2	w3	w4	z
FDX 26	230	116	M10	40	306	159	16°	29°	16,5°	35,5°	320
FDX 30	278	122	M10	50	330	183	15°	25°	12,5°	28,5°	367
FDX 40	360	138	M12	70	377	230	8,5°	16,5°	14°	12°	463

Dimensions in mm, Standard keyway in accordance with DIN 6885/1 - JS9
 *) Holding brake, **) Keyway in accordance with DIN 6885/3 - JS9

Brake / Construction Type	Electro-magnetic released Fail-Safe Spring Applied Brake		
	FDX 26	FDX 30	FDX 40
Name / Type	FDX 26	FDX 30	FDX 40
Version	Standard		
Protection Class	IP 67		
Max. ON Time	100%		
Ambient Temperature	-40 bis +40°C		
Max. Nominal Braking Torque (M _b) (Working Brake / Holding Brake)	250 / 375 Nm	500 / 850 Nm	1000 / 1500 Nm
Braking Torque during operation (deviation from M _b)	Static breaking torque: MbStat = Mb -10% / +30% Dynamic breaking torque: MbDyn = Mb ±20%		
Weight	30 kg	45 kg	80 kg
Moment of Inertia (rotor and hub)	6,65 x 10 ⁻³ kgm ²	19,5 x 10 ⁻³ kgm ²	44,5 x 10 ⁻³ kgm ²
Max. Speed (Working Brake / Holding Brake)	3000 / 6000 min ⁻¹		
Input Voltage	400 V AC		
Coil Voltage	180 V DC *)		
Max. Power (P, Release / Hold)	*): 560 / 140 W	*): 880 / 220 W	*): 1080 / 270 W
Life Time Friction Work until rotor exchange	2,8 x 10 ⁹ J	3,7 x 10 ⁹ J	4,0 x 10 ⁹ J
Air Gap Setting brand-new brake	0,5 ^{+0,2} mm	0,5 ^{+0,2} mm	0,6 ^{+0,2} mm
Air Gap maximum	1,9 mm	1,9 mm	1,7 mm
Braking Time DC / AC (=> DC-connected / AC-connected ***)	40 ms **) / 600 ms	60 ms **) / 800 ms	160 ms **) / 3 s
Release Time ***)	160 ms *)	140 ms *)	320 ms *)
Dimensions	See table on the left and data sheet M98-080		
Rectifier PMG 480	See data sheet T90-156		

Options:

Sensor / Micro switch data in acc. to T90-322 resp. T90-323	Sensor: 10...36 V DC / 200 mA Micro switch: Ue 230 V le 0,5 A // Ue 24 V le 0,6 A (Utilization category in acc. to EN 60947-5-1)		
Heating data	230 V AC / 70 W	230 V AC / 128 W	230 V AC / 180 W

*) operated with rectifier PMG 480 at 20°C
 **) new air gap setting and operated with rectifier PMG 480
 ***) the listed Braking Times and Release Times are average values (deviation ±30%)